

The Next Step in Belting

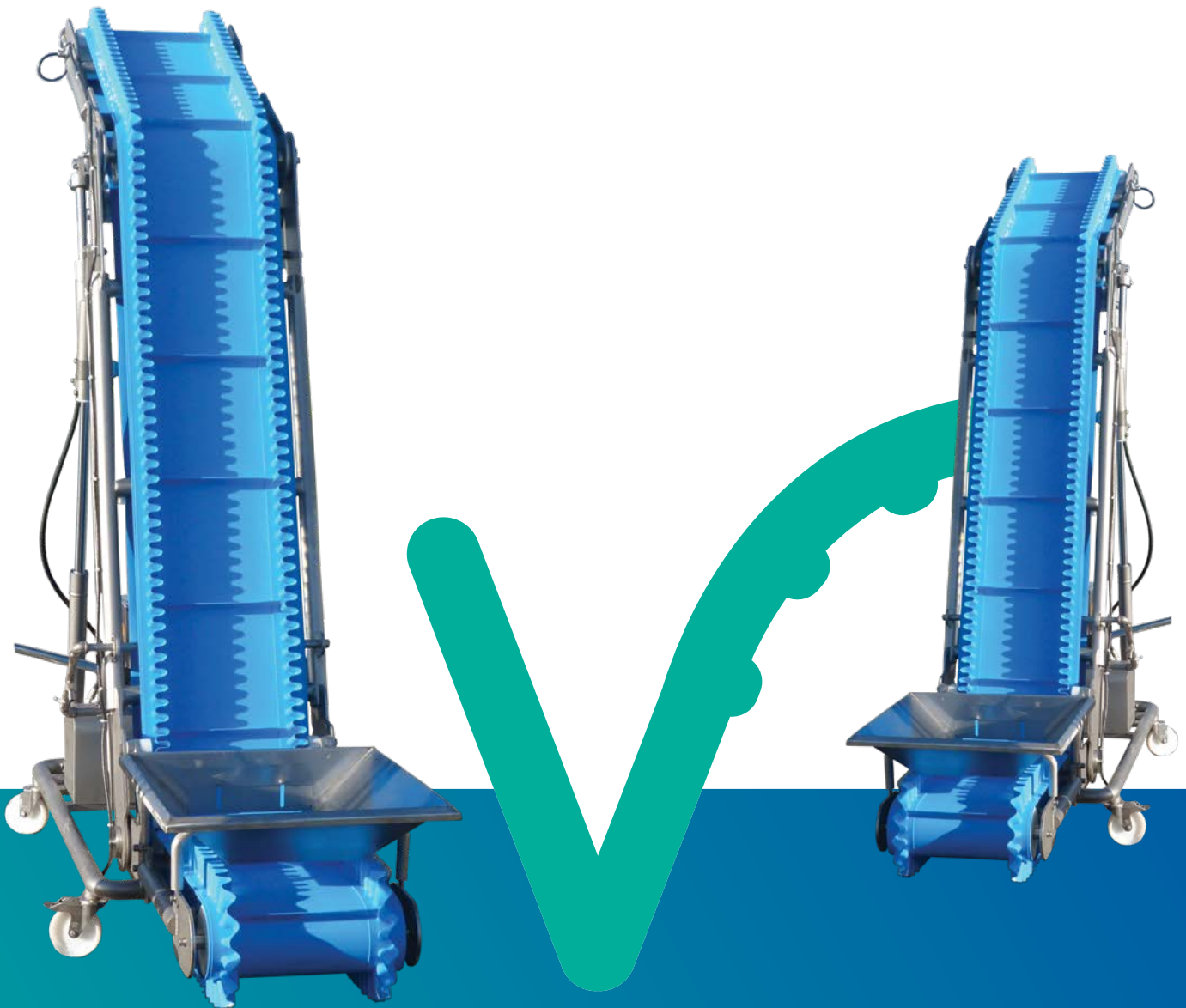

Food Grade
Positive Drive Line
Conveying Solutions

SuperDrive™

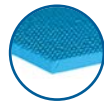

ITE
Impression
Top Embossed

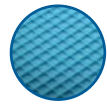

ITO-50
Impression
Top Oval



MC
Mini
Cleats

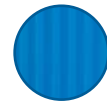

IRT
Impression
Roof Top

The homogeneous Positive Drive, recognized worldwide as the best choice where hygiene and conveying efficiency are essential.

Smooth Top SuperDrive™ Belts											
Product & Color		Shore Hardness	Temperature Range	Coefficient of Friction on UHMW	Thickness		Minimum Pulley Diameter		Maximum Pull Force		Certifications
					mm		mm	Inch	kg/cm	lbs/in	
FHB-SD	Blue 16	55D	-20°C to 90°C -5°F to 194°F	0.20	3		126	4 ³¹ / ₃₂	7	39.2	FDA/USDA/EU
					4		176	6 ¹⁵ / ₁₆	9	50.40	
					6		300	11 ¹³ / ₁₆	14	78.40	
FHW-SD	Off White	55D	-20°C to 90°C -5°F to 194°F	0.20	3		126	4 ³¹ / ₃₂	7	39.2	FDA/USDA/EU
					4		176	6 ¹⁵ / ₁₆	9	50.40	
FEHB-SD-ITM2	Blue 16	55D	-20°C to 90°C -5°F to 194°F	0.18	3		126	4 ³¹ / ₃₂	7	39.2	FDA/USDA/EU
					4		176	6 ¹⁵ / ₁₆	9	50.40	
FMB-SD	Blue	53D	-20°C to 70°C -5°F to 158°F	0.28	3		80	3 ¹ / ₄	6.25	35	FDA/USDA/EU
					4		120	4 ³ / ₄	8	44.80	
					6		240	9 ³ / ₄	12.50	70	
FMW-SD	Beige	53D	-20°C to 70°C -5°F to 158°F	0.28	3		80	3 ¹ / ₄	6.25	35	FDA/USDA/EU
					4		120	4 ³ / ₄	8	44.80	
FMB-SD	Blue 02	53D	-20°C to 70°C -5°F to 158°F	0.28	3		80	3 ¹ / ₄	6.25	35	FDA/USDA/EU
FEMB-SD-ITM2	Blue	53D	-20°C to 70°C -5°F to 158°F	0.22	3		80	3 ¹ / ₄	6.25	35	FDA/USDA/EU
					4		120	4 ³ / ₄	8	44.80	
Impression Top SuperDrive™ Belts											
FHB-SD-ITO50	Blue 16	55D	-20°C to 90°C -5°F to 194°F	0.20	3		126	4 ³¹ / ₃₂	7	39.2	FDA/USDA/EU
					4		176	6 ¹⁵ / ₁₆	9	50.40	
FHB-SD-ITE	Blue 16	55D	-20°C to 90°C -5°F to 194°F	0.20	3		126	4 ³¹ / ₃₂	7	39.2	FDA/USDA/EU
FMB-SD-ITO50	Blue	53D	-20°C to 70°C -5°F to 158°F	0.28	3		80	3 ¹ / ₄	6.25	35	FDA/USDA/EU
FMB-SD-ITE	Blue	53D	-20°C to 70°C -5°F to 158°F	0.28	3		80	3 ¹ / ₄	6.25	35	FDA/USDA/EU
FMB-SD-MC	Blue	53D	-20°C to 70°C -5°F to 158°F	0.28	3		100	4	6.25	35	FDA/USDA/EU
Hydrolysis & Chemical Resistant SuperDrive™ Belts											
FDR-SD-V1	Blue 15	53D	-20°C to 70°C -5°F to 158°F	0.28	3		100	4	6.5	36.3	FDA/USDA/EU
					4		130	5 ¹ / ₈	8.6	48.4	
FEDR-SD-ITM2-V1	Blue 15	53D	-20°C to 70°C -5°F to 158°F	0.22	3		100	4	6.5	36.3	FDA/USDA/EU
FEDR-SD-ITO50-V1	Blue 15	53D	-20°C to 70°C -5°F to 158°F	0.22	3		100	4	5.5	30.7	FDA/USDA/EU
FDR-SD-IRT-V1	Blue 15	53D	-20°C to 70°C -5°F to 158°F	0.22	4		140	5 ¹ / ₂	6.5	36.3	FDA/USDA/EU
Low Temperature (LT) SuperDrive™ Belts											
FMB-SD-LT	Blue 15	95A/46D	-35°C to 65°C -31°F to 149°F	0.30	3		80	3 ¹ / ₄	3	16.80	FDA/EU
Metal Detectable (MD) SuperDrive™ Belt											
FMB-SD-MD	Blue 09	53D	-20°C to 60°C -5°F to 140°F	0.28	3		100	4	6	33.6	FDA/EU
FMB-SD-ITO50-MD	Blue 09	53D	-20°C to 60°C -5°F to 140°F	0.28	3		100	4	6	33.6	FDA/EU

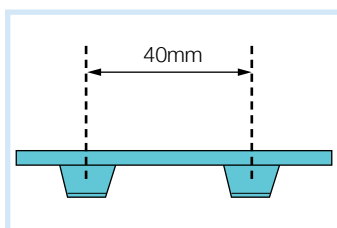

Pitch size for reference only

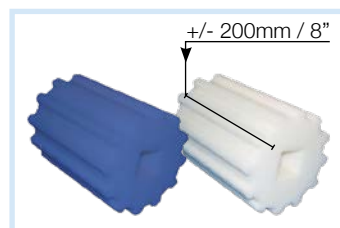

SuperDrive™ Drive Pulley

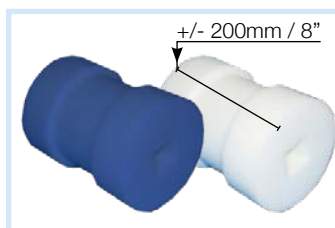

SuperDrive™ Tail Pulley

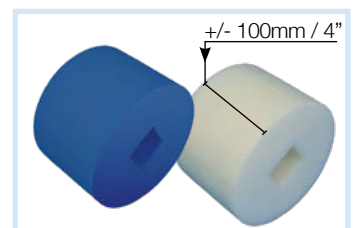

SuperDrive™ Support Pulley

Mini SuperDrive™

The only trackable Mini Positive Drive product.

The MiniSD™ design is similar to the world leader, Volta SuperDrive™; scaled down for a smaller minimum pulley. Standard belt width: 1524mm/60" or 2032mm/80". Please contact Volta Belting representative for additional information.

Smooth Top Mini SuperDrive™ Belts											
Product & Color			Shore Hardness	Temperature Range***	Coefficient of Friction on UHMW	Thickness	Minimum Pulley Diameter*		Maximum Pull Force**		Certifications
						mm	mm	Inch	kg/cm	lbs/in	
FMB-MSD	Blue		95A/46D	-20°C to 70°C -5°F to 158°F	0.28	2.5	48	1.89	4	22.4	FDA/USDA/EU

Impression Top Mini SuperDrive™ Belts											
FMB-MSD-ITO50	Blue		95A/46D	-20°C to 70°C -5°F to 158°F	0.28	2.5	48	1.89	4	22.4	FDA/USDA/EU
FMB-MSD-MC	Blue		95A/46D	-20°C to 70°C -5°F to 158°F	0.28	2.5	80	3.15	4	22.4	FDA/USDA/EU

Note: * Minimum Pulley Diameter – Normal Flex. Dimensions are relevant for an ambient temperature above 0°C / 32°F.

** Maximum Pull Force – in kg/cm width & lb/in width.

***To determine the allowable Pull force, check the "Temperature Correction Factor" table.

Declaration of Conformity in compliance with Food Contact Regulations: EU No.-10/2011 amended by 2017/752, 1935/2004 and 2023/2006 and FDA Art. 21. CFR.177.2600. Compatible with HACCP principles.

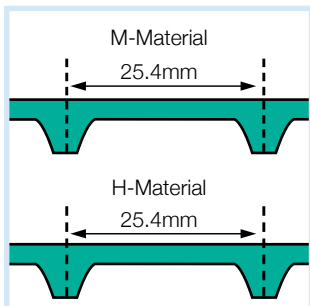

Pitch size for reference only

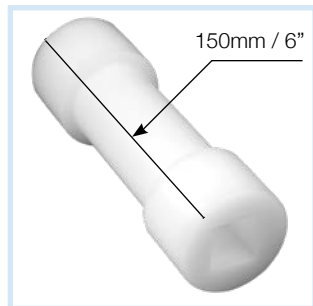

Tail Pulley

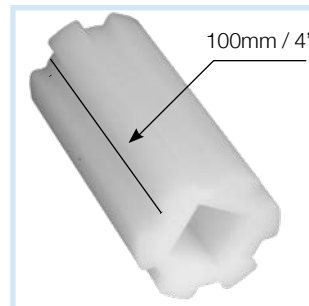

Drive Pulley

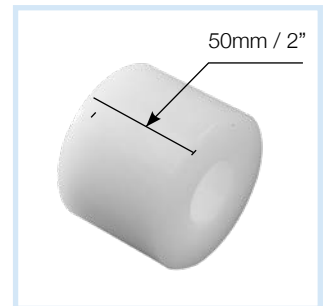

Support Pulley

Mini DualDrive™

A scaled-down version of the original DualDrive™ tooth geometry. Standard belt width: 2032mm/80".

Smooth Top Mini DualDrive™ Belts											
Product & Color			Shore Hardness	Temperature Range***	Coefficient of Friction on UHMW	Thickness	Minimum Pulley Diameter*		Maximum Pull Force**		Certifications
						mm	mm	Inch	kg/cm	lbs/in	
FMB-MDD	Blue		95A/46D	-20°C to 70°C -5°F to 158°F	0.28	2.5	48	1.89	4	22.4	FDA/USDA/EU

Impression Top Mini DualDrive™ Belts											
FMB-MDD-ITO50	Blue		95A/46D	-20°C to 70°C -5°F to 158°F	0.28	2.5	48	1.89	4	22.4	FDA/USDA/EU

Note: * Minimum Pulley Diameter – Normal Flex. Dimensions are relevant for an ambient temperature above 0°C / 32°F.

** Maximum Pull Force – in kg/cm width & lb/in width.

***To determine the allowable Pull force, check the "Temperature Correction Factor" table. Declaration of Conformity in compliance with Food Contact Regulations: EU No.-10/2011 amended by 2017/752, 1935/2004 and 2023/2006 and FDA Art. 21. CFR.177.2600. Compatible with HACCP principles.

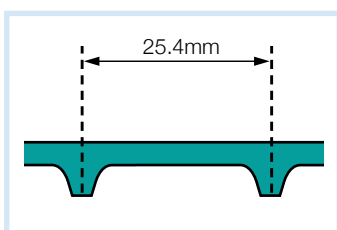

Pitch size for reference only



MDD Sprocket

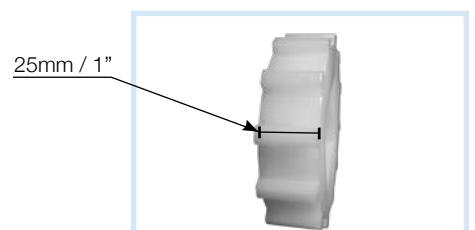

MDD Sprocket

DualDrive™

- Minimal retrofitting required. DualDrive™ is suited to some 2" pitch modular belt sprockets but for both reliability and hygiene these should be replaced.
- DualDrive™ is a fully extruded Positive Drive belt with drive teeth running the full width of the belt at a 2" pitch.

Mechanical Benefits:

- Replaces modular systems that require extensive cleaning and lengthy soaking and wear quickly at the joints.
- Greatly reduced noise levels in comparison with to modular belts.
- Integrated teeth for a Positive Drive with no slippage.
- No pretension of the belt is needed.
- Extruded in 30 or 60m (100 or 200ft) length and 1524mm (60") width.

Material Features:

- Smooth or textured homogeneous surface.
- Special texture available for non-stick applications.
- No ply/fraying of fibers.
- Easy and effective cleaning.
- No cracks or crevices that can potentially harbor bacteria.

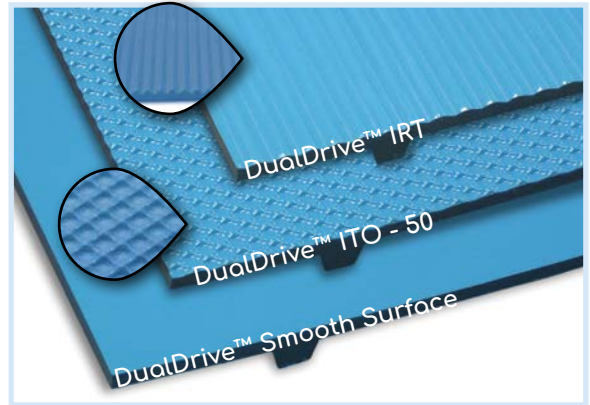

Smooth Top DualDrive™ Belts											
Product & Color		Shore Hardness	Temperature Range	Coefficient of Friction on UHMW	Thickness	Minimum Pulley Diameter		Maximum Pull Force		Certifications	
						mm	Inch	kg/cm	lbs/in		
FHB-DD	Blue 16	55D	-20°C to 90°C -5°F to 194°F	0.20	3	126	4 ³¹ / ₃₂	7	39.2	FDA/USDA/EU	
FMB-DD	Blue 02	53D	-20°C to 70°C -5°F to 158°F	0.28	3	80	3 ¹ / ₄	6	33.6	FDA/USDA/EU	
FMB-DD	Blue	53D	-20°C to 70°C -5°F to 158°F	0.28	3	80	3 ¹ / ₄	6	33.6	FDA/USDA/EU	
					4	120	4 ³ / ₄	7.7	43		
FMB-DD-ITM2	Blue	53D	-20°C to 70°C -5°F to 158°F	0.28	3	80	3 ¹ / ₄	6	33.6	FDA/USDA/EU	
FMW-DD	Beige	53D	-20°C to 70°C -5°F to 158°F	0.28	3	80	3 ¹ / ₄	6	33.6	FDA/USDA/EU	
FMW-DD-ITM2	Beige	53D	-20°C to 70°C -5°F to 158°F	0.28	3	80	3 ¹ / ₄	6	33.6	FDA/USDA/EU	
Impression Top DualDrive™ Belts											
FMB-DD-ITO50	Blue	53D	-20°C to 70°C -5°F to 158°F	0.28	3	80	3 ¹ / ₄	6	33.6	FDA/USDA/EU	
FMB-DD-IRT	Blue	53D	-20°C to 70°C -5°F to 158°F	0.28	4	100	4	6	33.6	FDA/USDA/EU	
Hydrolysis & Chemical Resistant DualDrive™ Belts											
FDR-DD-V1	Blue 15	53D	-20°C to 70°C -5°F to 158°F	0.28	3	100	4	6.5	36.3	FDA/USDA/EU	
FDR-DD-ITM2-V1	Blue 15	53D	-20°C to 70°C -5°F to 158°F	0.28	3	100	4	6.5	36.3	FDA/USDA/EU	
FDR-DD-ITM2-V1	Blue 15	53D	-20°C to 70°C -5°F to 158°F	0.28	3	100	4	6.5	36.3	FDA/USDA/EU	
Low Temperature (LT) DualDrive™ Bel											
FMB-DD-LT	Blue 15	95A/46D	-35°C to 65°C -31°F to 149°F	0.30	3	80	3 ¹ / ₄	3	16.80	FDA/EU	
Metal Detectable (MD) DualDrive™ Belt											
FMB-DD-MD	Blue 09	53D	-20°C to 60°C -5°F to 140°F	0.28	3	100	4	6	33.6	FDA/EU	

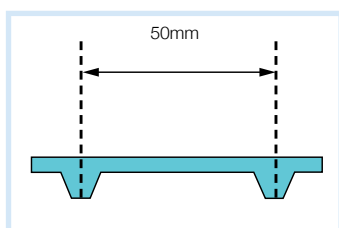

Pitch size for reference only

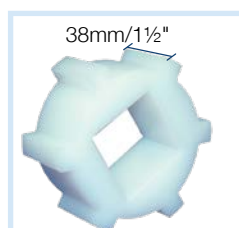

Machined Drive Sprockets



Machined Drive Sprockets



Molded Drive Sprocket



Molded Tail Roller

Volta RoundFlex™ Lace

New, improved geometry for a better grip on pulleys. Compatible with Volta MB, MW, MB-MD and DR material Flat and Positive Drive belts including MSD & MDD belts from 2.5 to 5mm thickness.

All Volta belt materials are easy to clean without removing from conveyor and therefore we only recommend lace when absolutely necessary. The strength of the belt will be affected at the joint where lace is used.

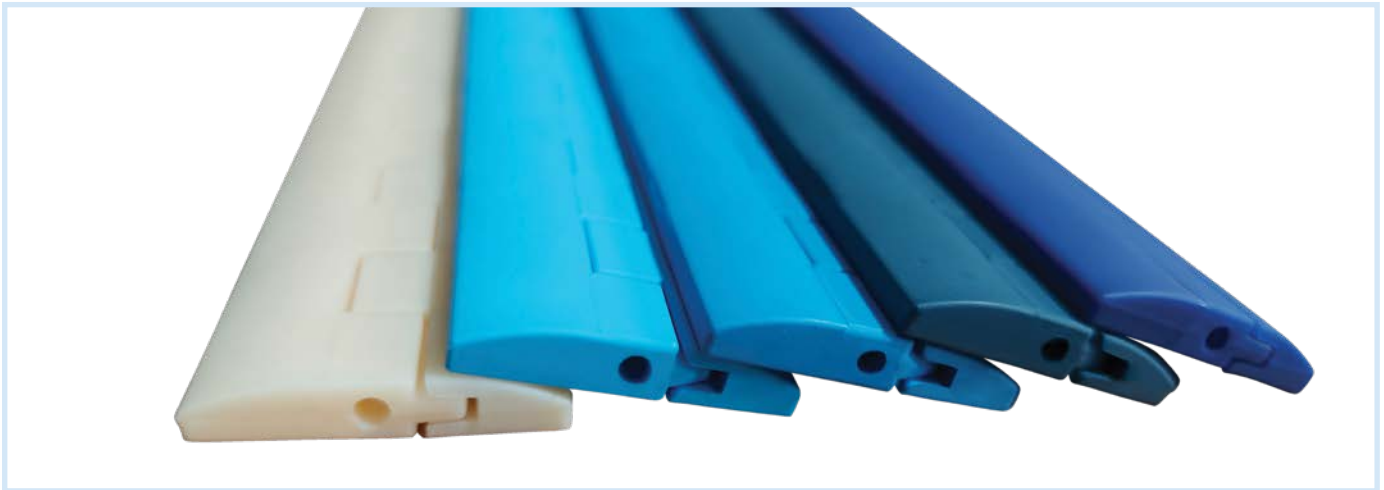

RoundFlex™ Lace

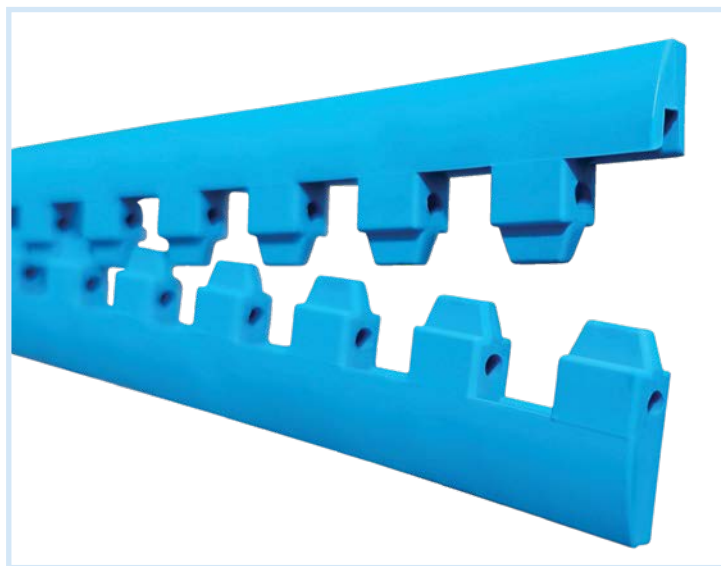

RoundFlex™ Lace

We are committed to providing a complete package focusing on servicing our customers all the way, up until the belts are safely installed and the conveyor is running smoothly.

Fabrications on Positive Drive Belts

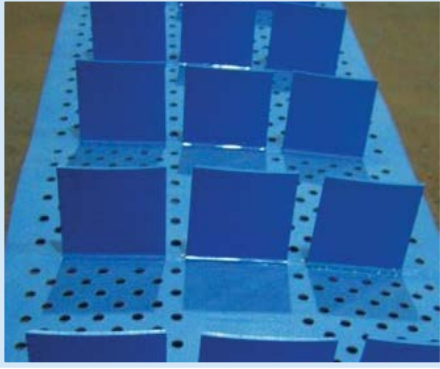

Perforated SuperDrive™
with Spaced Flights

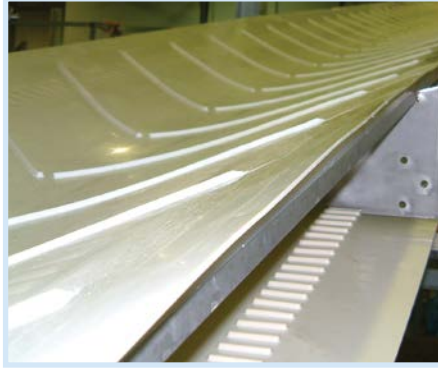

SuperDrive™ Trough Conveyor with
Chevron Flights



Perforated Mini DualDrive™ Belt



Mini SuperDrive™ Belt

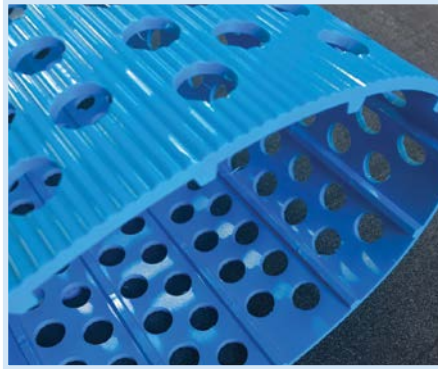

Perforated DD-IRT Belt

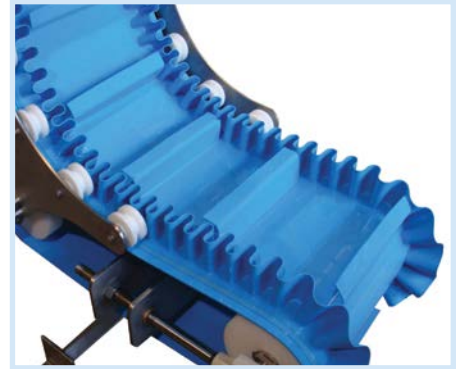

SuperDrive™ Z-elevator with Flights,
Guides and Sidewalls

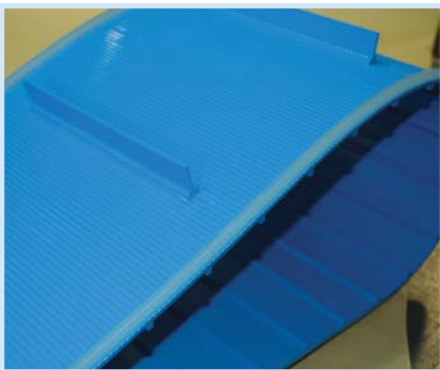

DualDrive™ with Impression Top IRT
Flights & Guides



SuperDrive™ with Flights Working
under Water



SuperDrive™ with Sidewalls
and Special Flights